



Medicon  
**... DieBLAUEN.**



Zerlegbare Stanzen mit Silikongriff

Dismantable Rongeurs with Silicone Handle

Pinzas saca-bocadas desmontables con mango de silicona

Pinces emporte-pièce démontables avec manche en silicone

Laminotomi smontabili con manico in silicone



# Medicon ... DieBLAUEN.

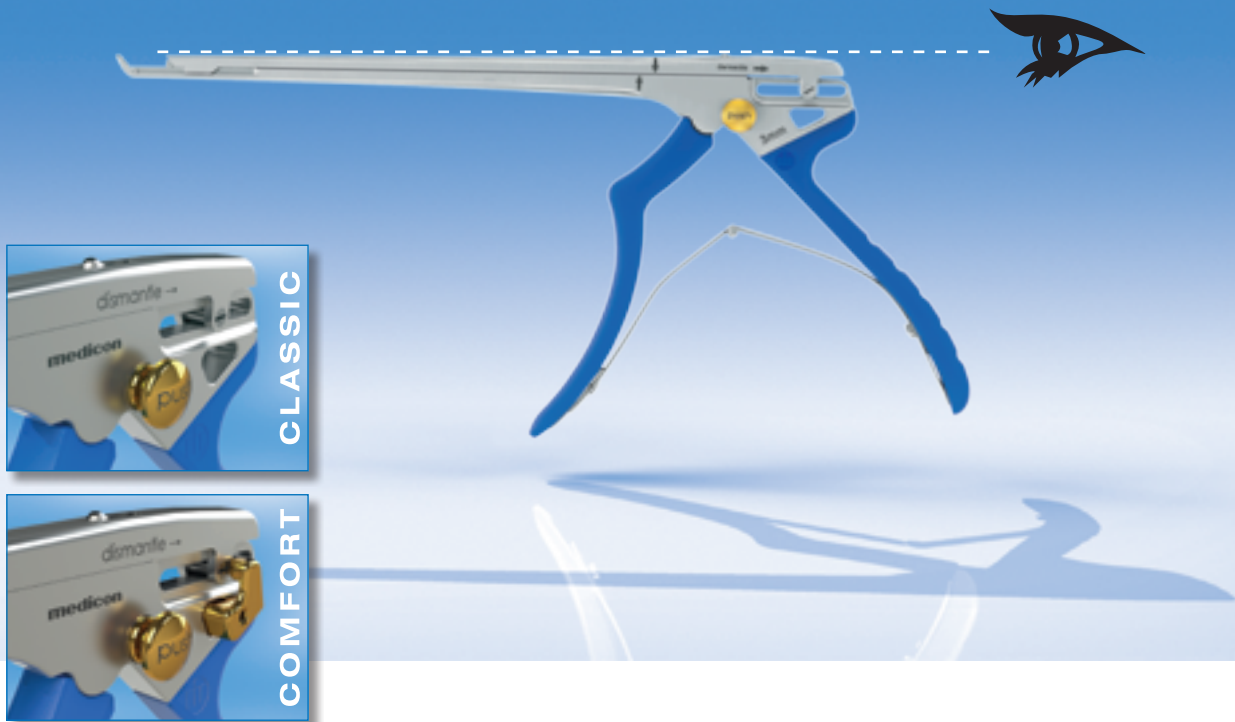

Medicon bietet mehrere Ausführungen der zerlegbaren Stanzen an. Die Modellreihen "CLASSIC" und "COMFORT" stehen jeweils mit breiter, schmaler oder extra schmaler Stanzplatte zur Verfügung. Die Stanzen der Modellreihe "COMFORT" sind zusätzlich mit einer Griffeinstellung ausgestattet, die es erlaubt, Griffweite und Maulöffnung in drei verschiedenen Stufen zu justieren.

Medicon offers various versions of the dismantable rongeurs. The "CLASSIC" and "COMFORT" lines are each available with thick, narrow or extra-narrow footplate. The rongeurs of the "COMFORT" line are additionally equipped with a three-step control element, that permits selecting from among three different levels of grip width and jaw opening.

Medicon ofrece varios modelos de pinzas desmontables. Las líneas de modelos "CLASSIC" y "COMFORT" están disponibles respectivamente con placa punzonadora ancha, estrecha y extra estrecha. Las pinzas de la línea de modelos "COMFORT" están provistas adicionalmente de un ajuste del mango, que permite regular el ancho del mango y la carrera en tres niveles distintos.

Medicon propose plusieurs modèles de pinces emporte-pièce démontables. Les modèles "CLASSIC" et "COMFORT" sont offerts avec un mors large, étroit ou très étroit. Les pinces du modèle "COMFORT" sont en outre équipées d'un réglage de poignée qui permet d'ajuster la largeur de préhension et l'ouverture des mors selon trois niveaux différents.

Medicon offre diverse versioni di laminotomi smontabili. Le serie "CLASSIC" e "COMFORT" sono disponibili con morso della pinza largo, sottile o extrasottile. I laminotomi della serie "COMFORT" possiedono inoltre un meccanismo di impostazione dell'impugnatura che consente di regolare l'apertura e la corsa dell'impugnatura in tre livelli diversi.

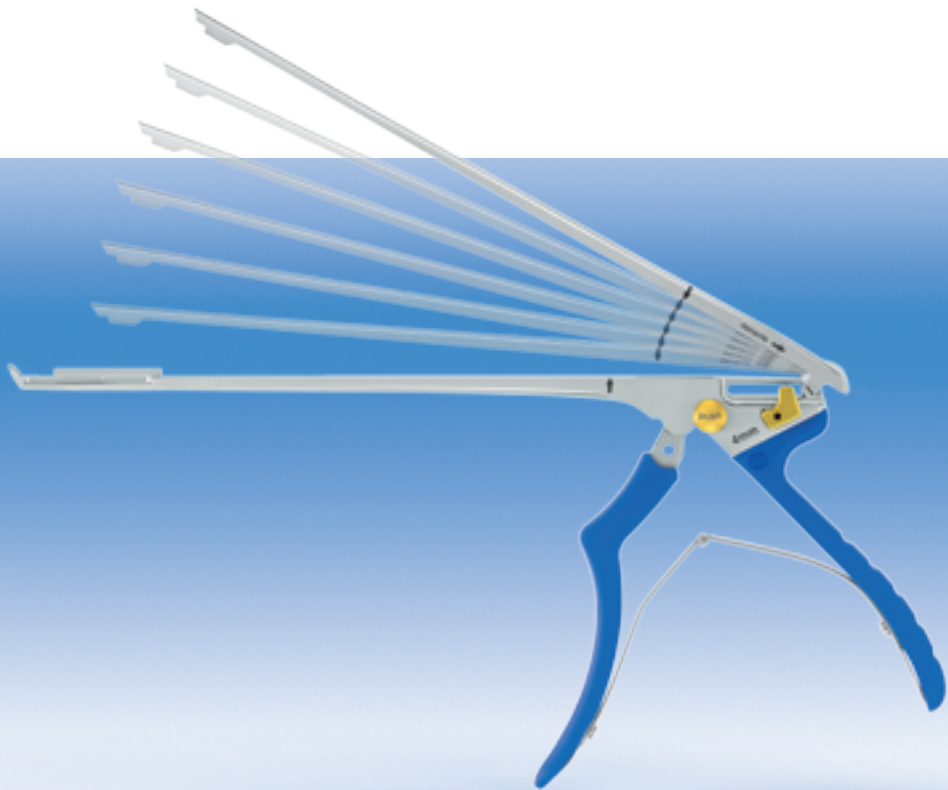

Einteilige Zerlegetechnik  
 One piece dismantable rongeur  
 Pinza saca-bocada desmontables de una sola pieza  
 Technique de démontage d'une pièce  
 Tecnica di smontaggio a monopezzo

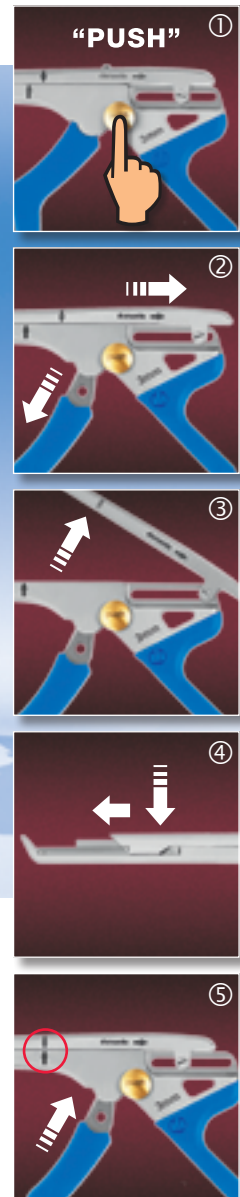

- ▶ Ergonomisches Design und Balance für höchste Präzision und Arbeitskomfort
- ▶ Flacher Schieber für optimale Sicht bei minimal-invasiven Eingriffen
- ▶ Einteilige Zerlegetechnik für einfache Demontage (1-3) und Montage (4-5)
  
- ▶ Ergonomic design and balance for high precision and working comfort
- ▶ Flat upper slide allows ideal visibility for minimally invasive surgery
- ▶ One piece dismantable rongeur for easy disassembling (1-3) and assembling (4-5)
  
- ▶ Diseño ergonómico e equilibrado para la máxima precisión y confort de trabajo
- ▶ Corredera plana posibilita una visión óptimal en intervenciones mínimamente invasivas
- ▶ Pinza saca-bocada desmontable de una sola pieza para un desmontaje (1-3) y montaje (4-5) sencillo
  
- ▶ Design et équilibre ergonomique pour une précision et un confort de travail maximal
- ▶ Coulisse plate pour une visibilité optimale lors des interventions mini-invasives
- ▶ Technique de démontage d'une pièce pour un démontage (1-3) et un montage (4-5) facile
  
- ▶ Disegno ed equilibrio ergonomico per altissima precisione e comfort lavorativo
- ▶ L'asta piatto permette un'ottima visione per interventi mini-invasivi
- ▶ Tecnica di smontaggio a monopezzo per uno smontaggio (1-3) e montaggio (4-5) facile



# Medicon ... DieBLAUEN.

Stanzen mit regulierbarer Griffweite und Maulöffnung  
 Rongeurs with adjustable grip width and jaw opening  
 Pinzas saca-bocadas con ancho de mango y abertura ajustable  
 Pincas emporte-pièce à largeur de préhension et ouverture réglable  
 Laminotomi con larghezza dell'impugnatura e apertura del morso regolabile



## COMF O

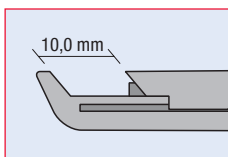
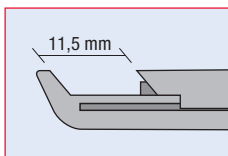
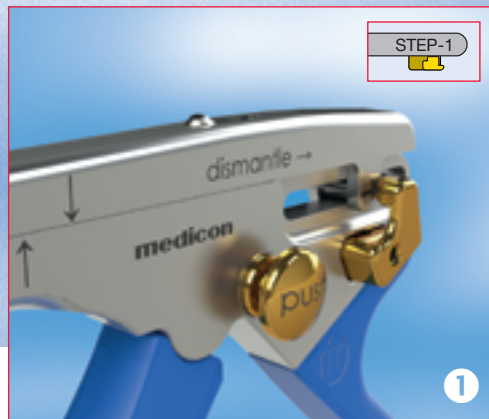
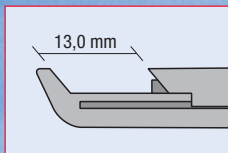

Dreistufige GriffEinstellung  
 Three-step control element  
 Elemento de mando de tres niveles  
 Element de commande à trois niveaux  
 Dispositivo di controllo a tre livelli

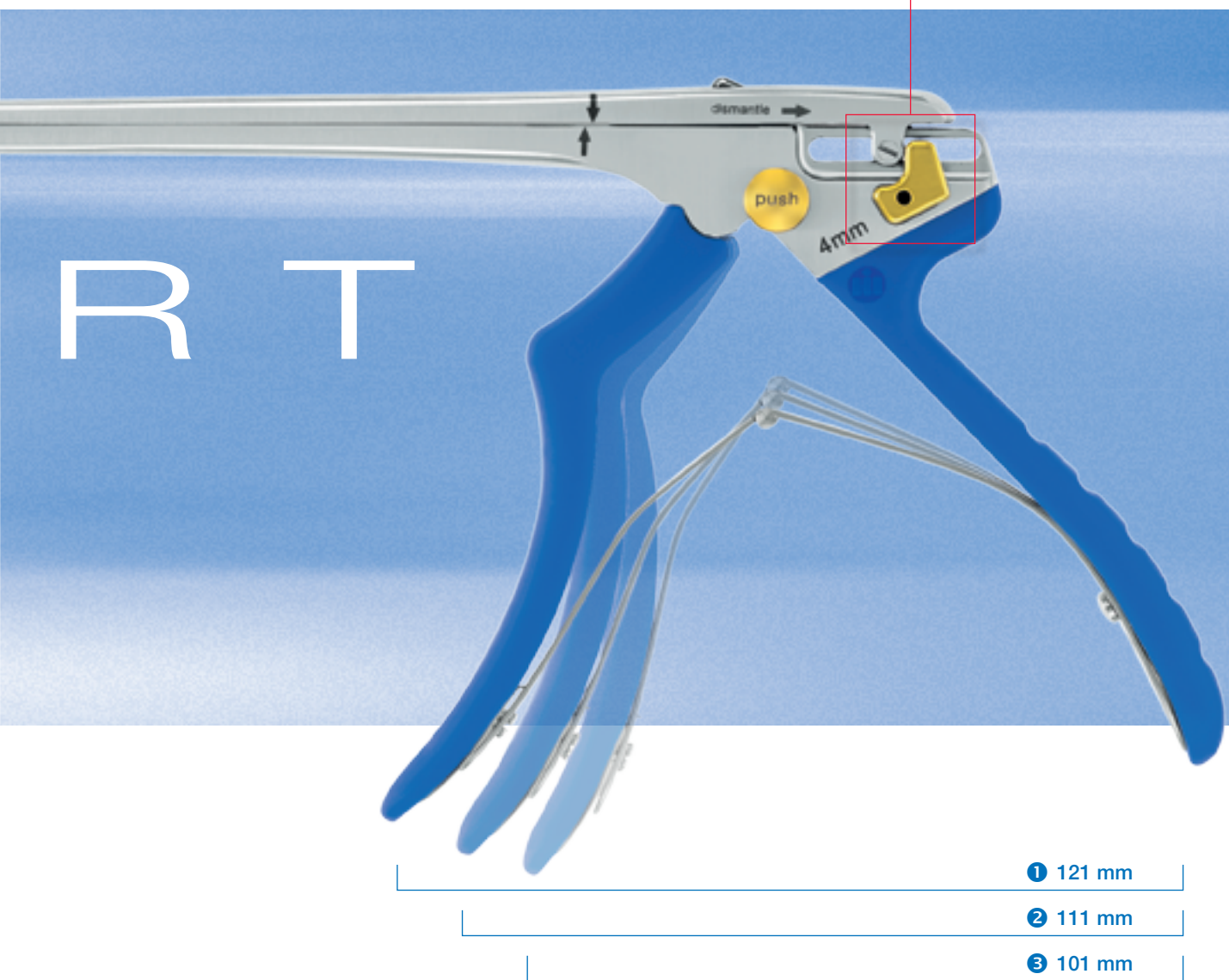

- ▶ Das neue Design ermöglicht ein kraftschonendes Öffnen und Schließen
- ▶ Komfortables Arbeiten durch Anpassung der Griffweite an unterschiedliche Handgrößen
- ▶ New design allows for effortless opening and closing
- ▶ Increased working convenience thanks to adjustable handles to meet all sizes of hands
- ▶ El nuevo diseño permite una abertura y cierre sin esfuerzo
- ▶ Trabajo cómodo gracias a la adaptación de la abertura del mango a los distintos tamaños de la mano
- ▶ Le nouveau design permet une ouverture et une fermeture en douceur
- ▶ Travail confortable grâce à l'ajustement de la largeur de préhension à différentes tailles de main
- ▶ Il nuovo disegno consente un'apertura e chiusura agevole
- ▶ Maneggevole grazie all'adattamento dell'impugnatura alle diverse dimensioni delle mani



# Medicon ... DieBLAUEN.



Farbkodierung  
Color coding  
Codificación de color  
Codage couleur  
Codice colore

## CLASSIC

## COMFORT

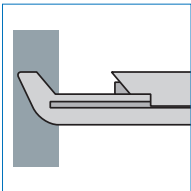

Breite Stanzplatte  
Thick footplate  
Lámina de punzonar ancha  
Plaque de poinçonnage large  
Morso largo



grau  
grey  
gris  
gris  
grigio

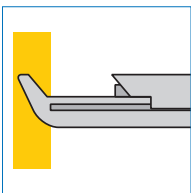

Schmale Stanzplatte  
Narrow footplate  
Lámina de punzonar estrecha  
Plaque de poinçonnage étroite  
Morso sottile



goldfarbig  
golden  
dorado  
doré  
dorato

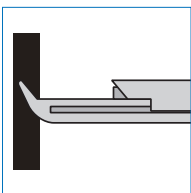

Extra schmale Stanzplatte  
Extra narrow footplate  
Lámina de punzonar extra estrecha  
Plaque de poinçonnage extra étroite  
Morso extra sottile



schwarz  
black  
negra  
noir  
nero



**Zerlegbare Stanzen mit Silikongriff**  
**Dismantable Rongeurs with Silicone Handle**  
**Pinzas saca-bocadas desmontables con mango de silicona**  
**Pinces emporte-pièce démontables avec manche en silicone**  
**Laminotomi smontabili con manico in silicone**





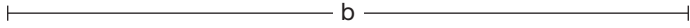



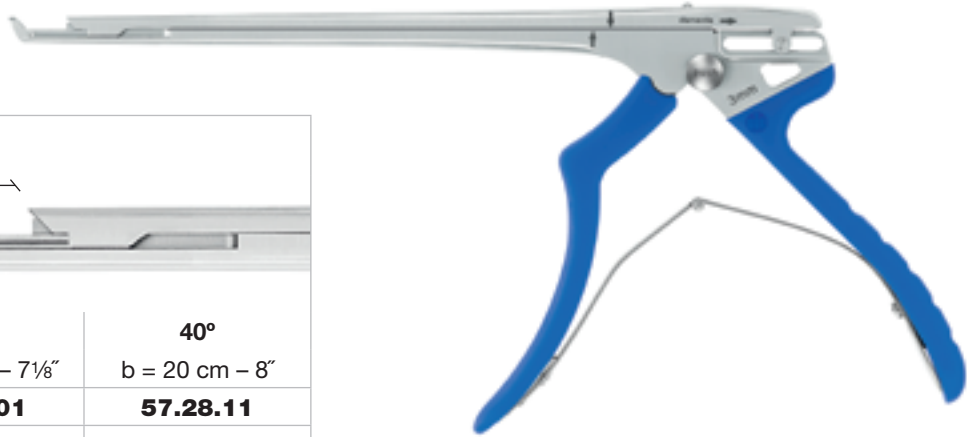



Stanzbreite Jaw width Ancho del corte Largeur des mors Larghezza del taglio	D	
	40° a	40° b
1 mm	b = 18 cm - 7 1/8"	b = 20 cm - 8"
2 mm	<b>57.28.01</b>	<b>57.28.11</b>
3 mm	<b>57.28.02</b>	<b>57.28.12</b>
4 mm	<b>57.28.03</b>	<b>57.28.13</b>
5 mm	<b>57.28.04</b>	<b>57.28.14</b>
6 mm	<b>57.28.05</b>	<b>57.28.15</b>
6 mm	<b>57.28.06</b>	<b>57.28.16</b>

**Kerrison**  
**CLASSIC**

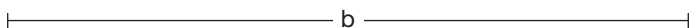







Stanzbreite Jaw width Ancho del corte Largeur des mors Larghezza del taglio	D	
	40° a	40° b
1 mm	b = 18 cm - 7 1/8"	b = 20 cm - 8"
2 mm	<b>57.28.01A</b>	<b>57.28.11A</b>
3 mm	<b>57.28.02A</b>	<b>57.28.12A</b>
4 mm	<b>57.28.03A</b>	<b>57.28.13A</b>
5 mm	<b>57.28.04A</b>	<b>57.28.14A</b>
6 mm	<b>57.28.05A</b>	<b>57.28.15A</b>
6 mm	<b>57.28.06A</b>	<b>57.28.16A</b>

**Kerrison**  
**COMFORT**

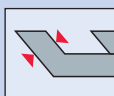

Breite Stanzplatte  
 Thick footplate  
 Lámina de punzonar ancha  
 Plaque de poinçonnage large  
 Morso largo



mit Auswerfer  
 with ejector  
 con expulsor  
 avec éjecteur  
 con espulsore

**Zerlegbare Stanzen mit Silikongriff**  
**Dismantable Rongeurs with Silicone Handle**  
**Pinzas saca-bocadas desmontables con mango de silicona**  
**Pinces emporte-pièce démontables avec manche en silicone**  
**Laminotomi smontabili con manico in silicone**

21  
8  
20  
19  
18  
7  
17  
16  
6  
15  
14  
5  
13  
12  
11  
4  
10  
9  
3  
8  
7  
6  
2  
5  
4  
3  
1  
2  
1  
cm  
inch

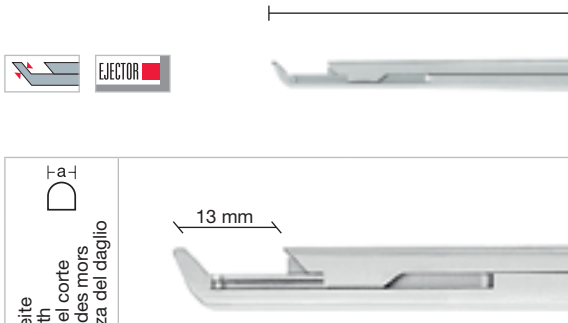

Stanzbreite Jaw width Ancho del corte Largeur des mors Larghezza del daglio	40°	
	b = 18 cm – 7 1/8"	b = 20 cm – 8"
a 1,0 mm	<b>57.28.21</b>	<b>57.28.31</b>
1,5 mm	<b>57.27.91</b>	<b>57.27.92</b>
2,0 mm	<b>57.28.22</b>	<b>57.28.32</b>
3,0 mm	<b>57.28.23</b>	<b>57.28.33</b>
4,0 mm	<b>57.28.24</b>	<b>57.28.34</b>
5,0 mm	<b>57.28.25</b>	<b>57.28.35</b>
6,0 mm	<b>57.28.26</b>	<b>57.28.36</b>



**Kerrison**  
**CLASSIC**

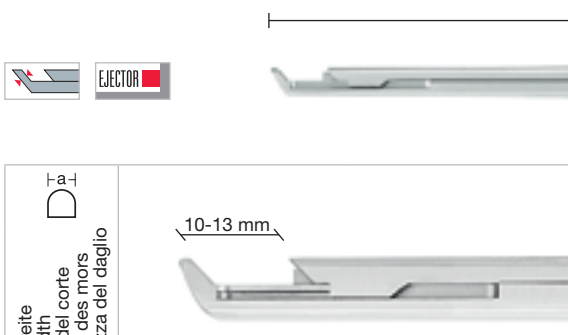

Stanzbreite Jaw width Ancho del corte Largeur des mors Larghezza del daglio	40°	
	b = 18 cm – 7 1/8"	b = 20 cm – 8"
a 1,0 mm	<b>57.28.21A</b>	<b>57.28.31A</b>
1,5 mm	<b>57.27.91A</b>	<b>57.27.92A</b>
2,0 mm	<b>57.28.22A</b>	<b>57.28.32A</b>
3,0 mm	<b>57.28.23A</b>	<b>57.28.33A</b>
4,0 mm	<b>57.28.24A</b>	<b>57.28.34A</b>
5,0 mm	<b>57.28.25A</b>	<b>57.28.35A</b>
6,0 mm	<b>57.28.26A</b>	<b>57.28.36A</b>

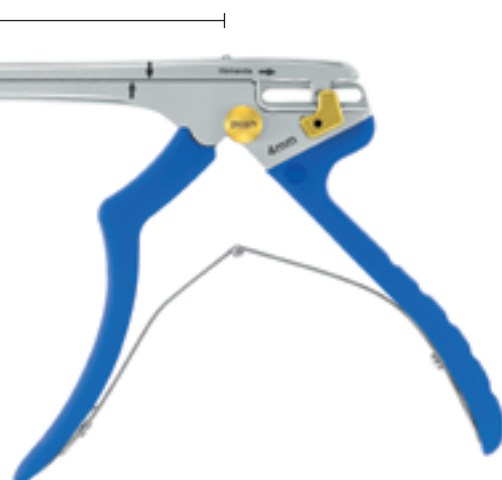

**Kerrison**  
**COMFORT**

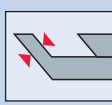

 Schmale Stanzplatte  
 Narrow footplate  
 Lámina de punzonar estrecha  
 Plaque de poinçonnage étroite  
 Morso sottile

 mit Auswerfer  
 with ejector  
 con espulsore  
 avec éjecteur  
 con espulsore



**Zerlegbare Stanzen mit Silikongriff**  
**Dismantable Rongeurs with Silicone Handle**  
**Pinzas saca-bocadas desmontables con mango de silicona**  
**Pinces emporte-pièce démontables avec manche en silicone**  
**Laminotomi smontabili con manico in silicone**





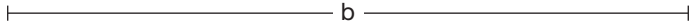



90°  
b = 18 cm - 7 1/8"



Stanzbreite Jaw width Ancho del corte Largeur des mors Larghezza del daglio	a
1 mm	<b>57.28.41</b>
2 mm	<b>57.28.42</b>
3 mm	<b>57.28.43</b>
4 mm	<b>57.28.44</b>
5 mm	<b>57.28.45</b>
6 mm	<b>57.28.46</b>

**Kerrison**  
**CLASSIC**



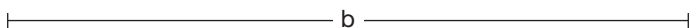

90°  
b = 18 cm - 7 1/8"



Stanzbreite Jaw width Ancho del corte Largeur des mors Larghezza del daglio	a
1 mm	<b>57.28.41A</b>
2 mm	<b>57.28.42A</b>
3 mm	<b>57.28.43A</b>
4 mm	<b>57.28.44A</b>
5 mm	<b>57.28.45A</b>
6 mm	<b>57.28.46A</b>

**Kerrison**  
**COMFORT**

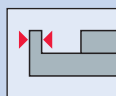



Schmale Stanzplatte  
Narrow footplate  
Lámina de punzonar estrecha  
Plaque de poinçonnage étroite  
Morso sottile



mit Auswerfer  
with ejector  
con expulsor  
avec éjecteur  
con espulsore

**Zerlegbare Stanzen mit Silikongriff**  
**Dismantable Rongeurs with Silicone Handle**  
**Pinzas saca-bocadas desmontables con mango de silicona**  
**Pinces emporte-pièce démontables avec manche en silicone**  
**Laminotomi smontabili con manico in silicone**

21  
8  
20  
19  
18  
7  
17  
16  
6  
15  
14  
5  
13  
12  
4  
10  
9  
3  
7  
6  
2  
5  
4  
1  
3  
2  
1  
cm inch



Stanzbreite Jaw width Ancho del corte Largeur des mors Larghezza del daglio	magic cut		
	40°	40°	40°
a	b = 18 cm - 7 1/8"	b = 20 cm - 8"	b = 23 cm - 9"
1 mm	<b>57.28.51</b>	<b>57.28.61</b>	<b>57.29.61</b>
2 mm	<b>57.28.52</b>	<b>57.28.62</b>	<b>57.29.62</b>
3 mm	<b>57.28.53</b>	<b>57.28.63</b>	<b>57.29.63</b>
4 mm	<b>57.28.54</b>	<b>57.28.64</b>	<b>57.29.64</b>
5 mm	<b>57.28.55</b>	<b>57.28.65</b>	<b>57.29.65</b>
6 mm	<b>57.28.56</b>	<b>57.28.66</b>	<b>57.29.66</b>



**Kerrison**  
**CLASSIC**



Lange Standzeit, hohe Oberflächenhärte und blendfreie Oberfläche  
 Long lasting cutting ability, high surface hardness and non-dazzling surface  
 Máxima duración del corte, alta dureza de la superficie y superficie antideslumbrante  
 Longue durée de vie, grande dureté de la surface et surface non-éblouissante  
 Massima durata del taglio, alta durezza della superficie e superficie antiriflesso

Stanzbreite Jaw width Ancho del corte Largeur des mors Larghezza del daglio	magic cut		
	40°	40°	40°
a	b = 18 cm - 7 1/8"	b = 20 cm - 8"	b = 23 cm - 9"
1 mm	<b>57.28.51A</b>	<b>57.28.61A</b>	<b>57.29.61A</b>
2 mm	<b>57.28.52A</b>	<b>57.28.62A</b>	<b>57.29.62A</b>
3 mm	<b>57.28.53A</b>	<b>57.28.63A</b>	<b>57.29.63A</b>
4 mm	<b>57.28.54A</b>	<b>57.28.64A</b>	<b>57.29.64A</b>
5 mm	<b>57.28.55A</b>	<b>57.28.65A</b>	<b>57.29.65A</b>
6 mm	<b>57.28.56A</b>	<b>57.28.66A</b>	<b>57.29.66A</b>

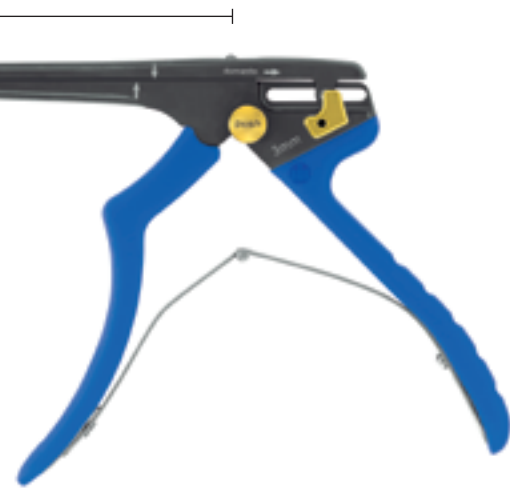

**Kerrison**  
**COMFORT**

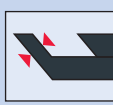

Schmale Stanzplatte  
 Narrow footplate  
 Lámina de punzonar estrecha  
 Plaque de poinçonnage étroite  
 Morso sottile



mit Auswerfer  
 with ejector  
 con espulsore  
 avec éjecteur  
 con espulsore

**Zerlegbare Stanzen mit Silikongriff**  
**Dismantable Rongeurs with Silicone Handle**  
**Pinzas saca-bocadas desmontables con mango de silicona**  
**Pinces emporte-pièce démontables avec manche en silicone**  
**Laminotomi smontabili con manico in silicone**



b

13 mm

90°

b = 18 cm - 7 1/8"

Stanzbreite Jaw width Ancho del corte Largeur des mors Larghezza del daglio					
	D	Ta-I	<b>magic cut</b>		
a			b = 18 cm - 7 1/8"		
1 mm			<b>57.28.71</b>		
2 mm			<b>57.28.72</b>		
3 mm			<b>57.28.73</b>		
4 mm			<b>57.28.74</b>		
5 mm			<b>57.28.75</b>		
6 mm			<b>57.28.76</b>		

**Kerrison**

**CLASSIC**



Lange Standzeit, hohe Oberflächenhärte und blendfreie Oberfläche  
 Long lasting cutting ability, high surface hardness and non-dazzling surface  
 Máxima duración del corte, alta dureza de la superficie y superficie antideslumbrante  
 Longue durée de vie, grande dureté de la surface et surface non-éblouissante  
 Massima durata del taglio, alta durezza della superficie e superficie antiriflesso

b

10-13 mm

90°

b = 18 cm - 7 1/8"

Stanzbreite Jaw width Ancho del corte Largeur des mors Larghezza del daglio					
	D	Ta-I	<b>magic cut</b>		
a			b = 18 cm - 7 1/8"		
1 mm			<b>57.28.71A</b>		
2 mm			<b>57.28.72A</b>		
3 mm			<b>57.28.73A</b>		
4 mm			<b>57.28.74A</b>		
5 mm			<b>57.28.75A</b>		
6 mm			<b>57.28.76A</b>		

**Kerrison**

**COMFORT**

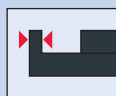

Schmale Stanzplatte  
 Narrow footplate  
 Lámina de punzonar estrecha  
 Plaque de poinçonnage étroite  
 Morso sottile



mit Auswerfer  
 with ejector  
 con expulsor  
 avec éjecteur  
 con espulsore

**Zerlegbare Stanzen mit Silikongriff**  
**Dismantable Rongeurs with Silicone Handle**  
**Pinzas saca-bocadas desmontables con mango de silicona**  
**Pinces emporte-pièce démontables avec manche en silicone**  
**Laminotomi smontabili con manico in silicone**

21  
8  
20  
19  
18  
7  
17  
16  
6  
15  
14  
5  
13  
12  
11  
4  
10  
9  
3  
8  
7  
6  
2  
5  
4  
3  
1  
2  
1  
cm | inch

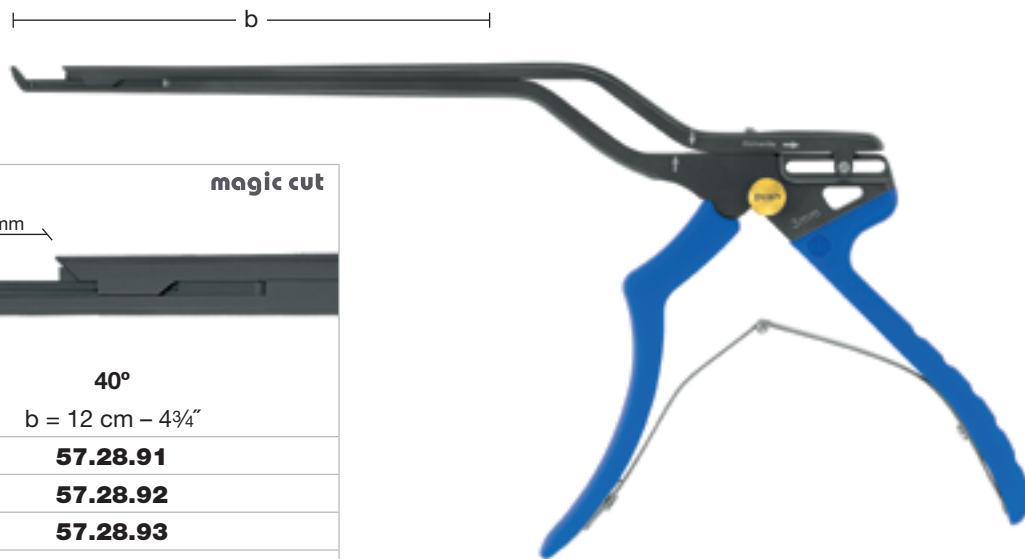

**EJECTOR**

Stanzbreite Jaw width Ancho del corte Largeur des mors Larghezza del daglio	magic cut
a	13 mm
	40°
	b = 12 cm – 4¾"
1 mm	<b>57.28.91</b>
2 mm	<b>57.28.92</b>
3 mm	<b>57.28.93</b>
4 mm	<b>57.28.94</b>
5 mm	<b>57.28.95</b>
6 mm	<b>57.28.96</b>

**Kerrison**  
**CLASSIC**

**magic cut**

Lange Standzeit, hohe Oberflächenhärte und blendfreie Oberfläche  
 Long lasting cutting ability, high surface hardness and non-dazzling surface  
 Máxima duración del corte, alta dureza de la superficie y superficie antideslumbrante  
 Longue durée de vie, grande dureté de la surface et surface non-éblouissante  
 Massima durata del taglio, alta durezza della superficie e superficie antiriflesso

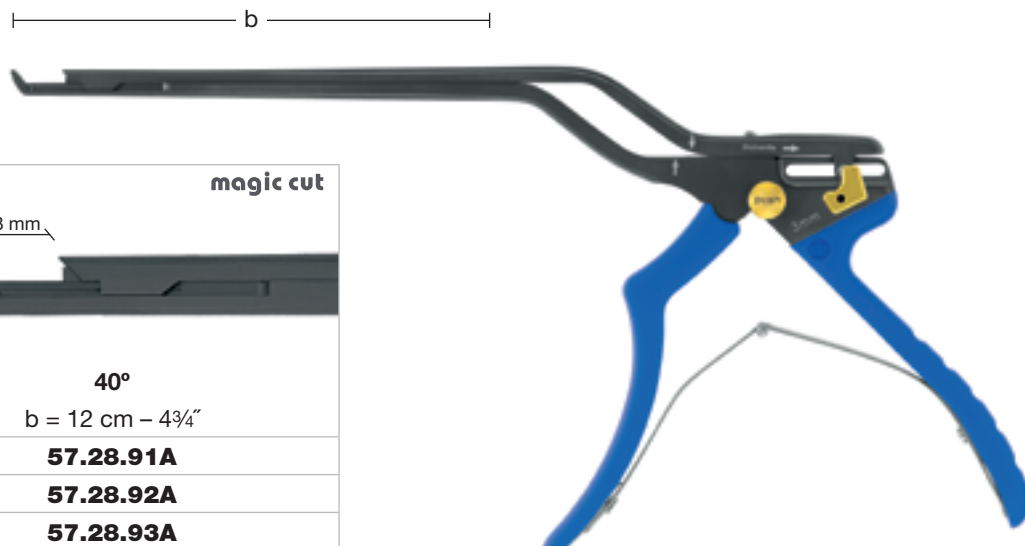

**EJECTOR**

Stanzbreite Jaw width Ancho del corte Largeur des mors Larghezza del daglio	magic cut
a	10-13 mm
	40°
	b = 12 cm – 4¾"
1 mm	<b>57.28.91A</b>
2 mm	<b>57.28.92A</b>
3 mm	<b>57.28.93A</b>
4 mm	<b>57.28.94A</b>
5 mm	<b>57.28.95A</b>
6 mm	<b>57.28.96A</b>

**Kerrison**  
**COMFORT**





Schmale Stanzplatte  
 Narrow footplate  
 Lámina de punzonar estrecha  
 Plaque de poinçonnage étroite  
 Morso sottile





mit Auswerfer  
 with ejector  
 con espulsore  
 avec éjecteur  
 con espulsore

**Zerlegbare Stanzen mit Silikongriff**  
**Dismantable Rongeurs with Silicone Handle**  
**Pinzas saca-bocadas desmontables con mango de silicona**  
**Pinces emporte-pièce démontables avec manche en silicone**  
**Laminotomi smontabili con manico in silicone**



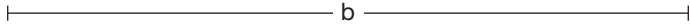









Stanzbreite Jaw width Ancho del corte Largeur des mors Larghezza del daglio		40° b = 18 cm – 7 1/8"	40° b = 20 cm – 8"
	a		
1 mm	<b>57.30.21</b>	<b>57.30.31</b>	
2 mm	<b>57.30.22</b>	<b>57.30.32</b>	
3 mm	<b>57.30.23</b>	<b>57.30.33</b>	
4 mm	<b>57.30.24</b>	<b>57.30.34</b>	

**Kerrison**  
CLASSIC



**FOR CERVICAL USE ONLY!**

Anwendung ausschließlich an der zervikalen Wirbelsäule!  
 For use on the cervical spine only!  
 Para uso exclusivo en la columna vertebral cervical!  
 Peuvent être utilisées exclusivement sur la colonne vertébrale cervicale!  
 Può essere utilizzato esclusivamente sulla colonna vertebrale cervicale!



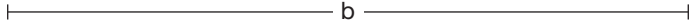



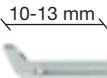

Stanzbreite Jaw width Ancho del corte Largeur des mors Larghezza del daglio		40° b = 18 cm – 7 1/8"	40° b = 20 cm – 8"
	a		
1 mm	<b>57.30.21A</b>	<b>57.30.31A</b>	
2 mm	<b>57.30.22A</b>	<b>57.30.32A</b>	
3 mm	<b>57.30.23A</b>	<b>57.30.33A</b>	
4 mm	<b>57.30.24A</b>	<b>57.30.34A</b>	

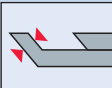

**Kerrison**  
COMFORT

 **Extra** schmale Stanzplatte  
**Extra** narrow footplate  
 Lámina de punzonar **extra** estrecha  
 Plaque de poinçonnage **extra** étroite  
 Morso **extra** sottile

 mit Auswerfer  
 with ejector  
 con espulsor  
 avec éjecteur  
 con espulsore

**Zerlegbare Stanzen mit Silikongriff**  
**Dismantable Rongeurs with Silicone Handle**  
**Pinzas saca-bocadas desmontables con mango de silicona**  
**Pinces emporte-pièce démontables avec manche en silicone**  
**Laminotomi smontabili con manico in silicone**

21  
8  
20  
19  
18  
7  
17  
16  
6  
15  
6  
14  
5  
13  
5  
12  
4  
11  
4  
10  
9  
3  
8  
3  
7  
2  
6  
2  
5  
4  
3  
1  
2  
1  
cm  
inch

Stanzbreite Jaw width Ancho del corte Largeur des mors Larghezza del daglio	magic cut		
	40°	40°	40°
a	b = 18 cm - 7 1/8"	b = 20 cm - 8"	b = 23 cm - 9"
1 mm	<b>57.30.51</b>	<b>57.30.61</b>	<b>57.30.71</b>
2 mm	<b>57.30.52</b>	<b>57.30.62</b>	<b>57.30.72</b>
3 mm	<b>57.30.53</b>	<b>57.30.63</b>	<b>57.30.73</b>
4 mm	<b>57.30.54</b>	<b>57.30.64</b>	<b>57.30.74</b>



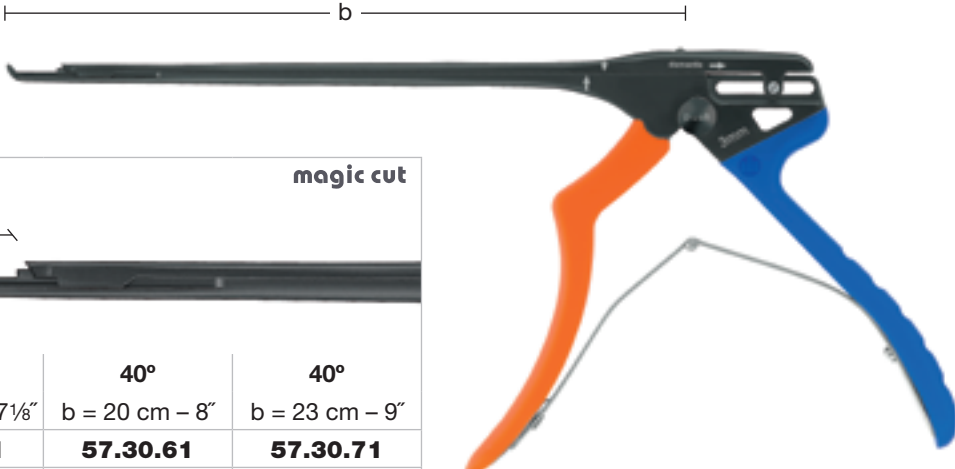

**Kerrison**  
**CLASSIC**

**FOR CERVICAL USE ONLY!**



Anwendung ausschließlich an der zervikalen Wirbelsäule!  
 For use on the cervical spine only!  
 Para uso exclusivo en la columna vertebral cervical!  
 Peuvent être utilisées exclusivement sur la colonne vertébrale cervicale!  
 Può essere utilizzato esclusivamente sulla colonna vertebrale cervicale!

Stanzbreite Jaw width Ancho del corte Largeur des mors Larghezza del daglio	magic cut		
	40°	40°	40°
a	b = 18 cm - 7 1/8"	b = 20 cm - 8"	b = 23 cm - 9"
1 mm	<b>57.30.51A</b>	<b>57.30.61A</b>	<b>57.30.71A</b>
2 mm	<b>57.30.52A</b>	<b>57.30.62A</b>	<b>57.30.72A</b>
3 mm	<b>57.30.53A</b>	<b>57.30.63A</b>	<b>57.30.73A</b>
4 mm	<b>57.30.54A</b>	<b>57.30.64A</b>	<b>57.30.74A</b>

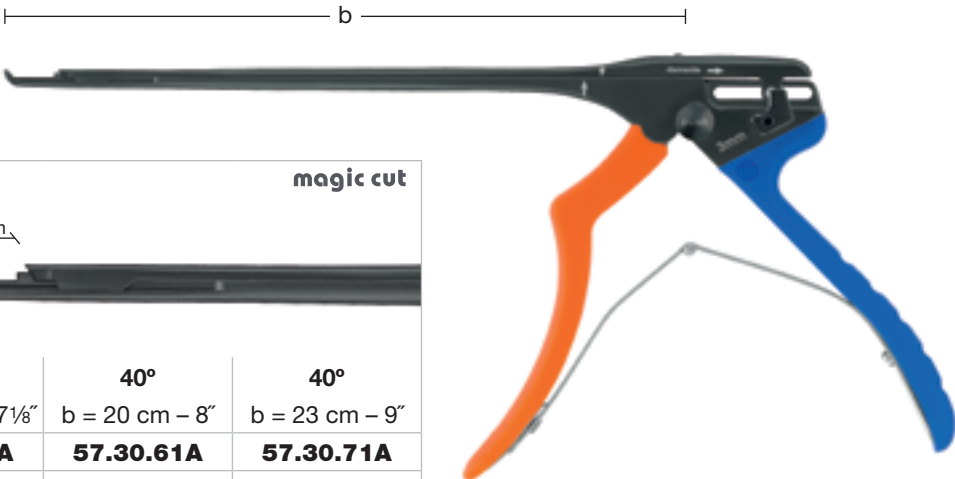

**Kerrison**  
**COMFORT**



Lange Standzeit, hohe Oberflächenhärte und blendfreie Oberfläche  
 Long lasting cutting ability, high surface hardness and non-dazzling surface  
 Máxima duración del corte, alta dureza de la superficie y superficie antideslumbrante  
 Longue durée de vie, grande dureté de la surface et surface non-éblouissante  
 Massima durata del taglio, alta durezza della superficie e superficie antiriflesso



**Extra** schmale Stanzplatte  
**Extra** narrow footplate  
 Lámina de punzonar **extra** estrecha  
 Plaque de poinçonnage **extra** étroite  
 Morso **extra** sottile



mit Auswerfer  
 with ejector  
 con espulsore  
 avec éjecteur  
 con espulsore

# www.medicon.de



Einen Überblick über das MEDICON-Gesamtprogramm finden Sie im Internet.

For general information on the complete MEDICON product range please refer to the Internet.

Una vista general de la gama completa de productos MEDICON puede encontrar en el Internet.

Une vue d'ensemble de la gamme complète des produits MEDICON se trouve sur notre site Internet.

Una visione generale della completa gamma dei prodotti MEDICON è visibile sul nostro site internet.

||| CMF

||| SURGICAL

||| NEURO+SPINE



**Medicon eG**

Gänsäcker 15  
D-78532 Tuttlingen

P. O. Box 44 55  
D-78509 Tuttlingen

Tel.: +49 (0) 74 62 / 20 09-0  
Fax: +49 (0) 74 62 / 20 09-50

E-Mail: [sales@medicon.de](mailto:sales@medicon.de)  
Internet: [www.medicon.de](http://www.medicon.de)

Germany

⚠ Not all products illustrated in this documentation are available for sale in all countries.  
Please contact your local distributor for more information.

Gedruckt in Deutschland  
Printed in Germany  
Impresso en Alemania  
Stampato in R.F.G.  
Trykket i Tyskland

Modelländerungen vorbehalten  
Patterns are subject to change  
Salvo modificaciones  
Tous droits réservés des changements de modèle  
Ci riserviamo la facoltà di cambiamenti nei modelli

© Copyright 06/2016, MEDICON eG, Tuttlingen, Germany

451 .04.57

**medicon**<sup>®</sup>

||| NEURO+SPINE

